

Spray wall type NFT

With dry filter type AV

Catalogue: NF03
Tab: 44
Page: 02.00

Description

The spray wall type NFT can be used for spray painting. Spray wall with dry filter is especially suited for small intensive spray painting.

The spray wall is made of galvanised steel sheet and delivered assembled.

The dry filter is an "Andrea" throw-away filter, which can be used for all painting types, glue, polyester etc.

The filtering degree is approx. 90 % and the filter can take up 20 kg solids per m².

The spray wall can also be delivered with labyrinth steel lamellas. If more filtering is wanted, a filter basket with replaceable filter mat can be mounted in the spray wall. Hinged side plates with a width of 600 mm can be mounted on the spray wall.

The spray wall can also be used as a fume panel. Beyond the dry spray wall programme DISA also can offer a complete wet spray cabin / sludge separator programme.

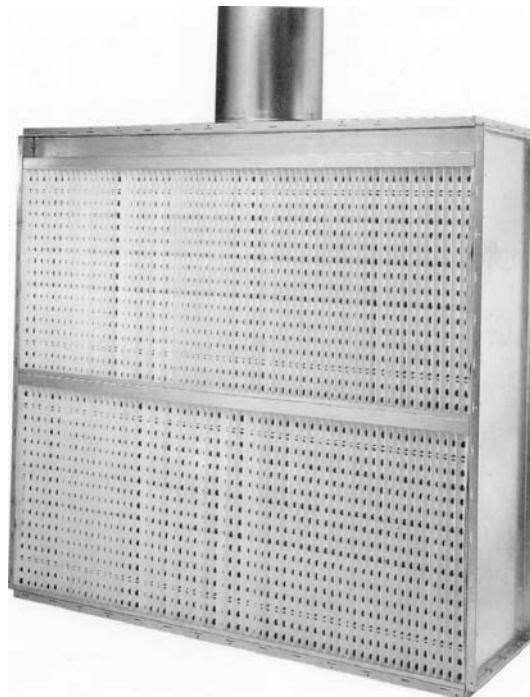

Version 1003GB

Advantages

- Compact construction
- High separation
- Maintainability
- Side plates as modular system (accessory)

Accessories

- Side plates
- Filter basket with replaceable filter mat
- Automatic blast gate
- QF system
- Fan
- Side module wall / ceiling
- Light fixture art. no. 49001.270
- Fresh-air inlet
- Electric control / automatic

Spray wall type NFT

With dry filter type AV

Catalogue: NF03
Tab: 44
Page: 02.01

Version 1003GB

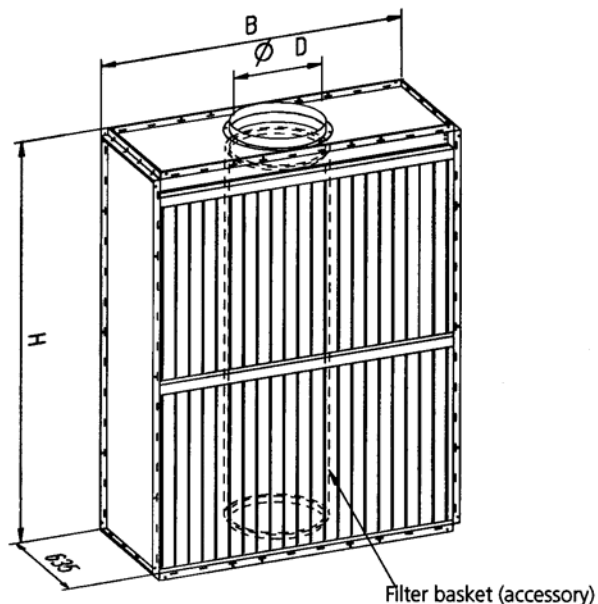

NFT 2000							
Type	Art. No.	H	B	ØD	m ³ /h at 0,5 m/s in the opening	Weight kg	* Pressure loss Pa start / slut
AV 1015	36040.0100	1120	1570	450 QF	3200	100	115 / 375
AV 1020	36040.0200	1120	2170	450 QF	4400	120	225 / 475
AV 1025	36040.0300	1120	2470	450 QF	5000	135	250 / 500
AV 1030	36040.0400	1120	3070	2 x 450 QF	6200	165	115 / 375
AV 1040	36040.0500	1120	4270	2 x 450 QF	8600	205	225 / 475
AV 2015	36080.0100	2020	1570	450 QF	5700	150	250 / 500
AV 2020	36080.0200	2020	2170	450 QF	7900	180	500 / 750
AV 2025	36080.0300	2020	2470	450 QF	9000	195	625 / 875
AV 2030	36080.0400	2020	3070	2 x 450 QF	11200	245	250 / 500
AV 2040	36080.0500	2020	4270	2 x 450 QF	15500	300	450 / 700

* Dry filter: pressure loss PA 25 / 100
* Filter basket: pressure loss Pa 25 / 200

Accessories

Filterbasket (1 basket / extraction branch)	
H	Art. No.
1120	36300.0501
2020	36300.0503

Spare parts

"Andrea – filter"	Art. no. 17000.005
Filter mat 2 x 20 m	Art. no. 07000.000
Clamp for filter mat	Art. no. 30408.362