

NFVZ (ATEX)

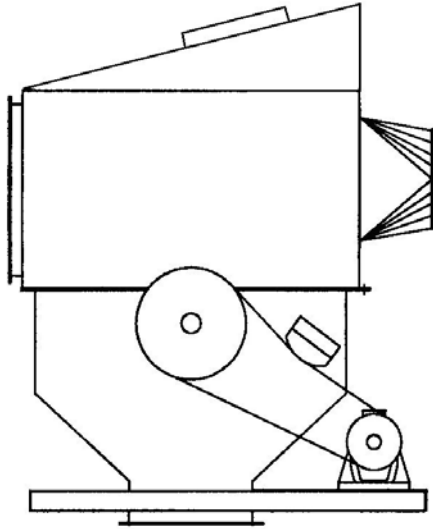

Application

Material separator type NFVZ is used where a combination of material transport and separation of fine explosive dust from basis material is required.

The material separator can be built into pneumatic transport systems, where pressureless outfeeding of the basis material for press, container or silo is required. The material separator can be used for e.g. paper, glass wool, chips etc.

The material separator type NFVZ is designed for ATEX zone 20 internal, but because of the connected components, the actual internal zone must be determined during planning. The correct zone will often be zone 22 or non-zone.

Description

The material separator is made of strong steel plate. The separator consists of a rotary valve and a coarse filter in perforated plate built in the wall of the valve housing. The rotor is mounted with special rubber packing's securing an air-tight valve for pressureless outfeeding. The transport air passes the coarse filter, which can be connected, to an air filter. The rotor secures continuous cleaning of the coarse filter. The explosion membranes are mounted on the top plate, 15° inclination.

Catalogue:Nf03

Tab: 22

Page: 02.00

Version 1000/GB

Advantages

- Pred max.: 0,3 bar
- Compact construction – the height of the construction is low
- High air and material flow
- Self cleaning
- Low effect consumption
- Pressureless material outfeeding
- ATEX approved

Ordering

At ordering please state the item no., type of separator, voltage and frequency of the power supply, operation specification, dimensions and weight, the Kst value of the dust and the installation zone.

Accessories

- COMBIFAB fans
- QF duct system
- Dust filters with automatic cleaning system
- Pressure sensor
- Thermo sensor - fire



Material Separator

NFVZ (ATEX)

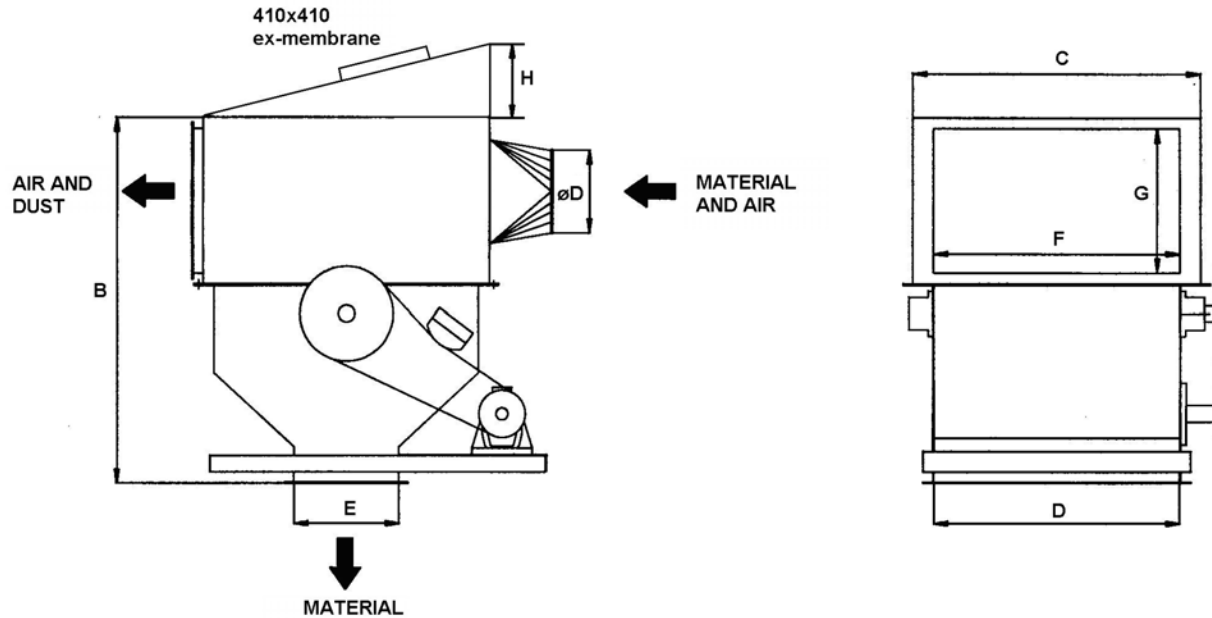
Specifications



Type	Air flow m ³ /h	Motor size kW	A (mm)	B (mm)	C (mm)	DxE (mm)	FxG (mm)	H (mm)	øD (mm)	Weight (kg)
NFVZ-3	3000	1.1	700	930	700	600x250	600x350	188	200 QF	235
NFVZ-7	7000	1.5	1080	1380	1080	920x385	920x530	290	315 QF	510
NFVZ-12	12000	2.2	1400	1760	1400	1200x500	1200x700	375	400 QF	740
NFVZ-20	20000	4.0	1800	2345	1800	1550x650	1550x910	483	500 QF	1250

Item no. *	NFVZ type	Number of ex- membranes 410x410	ATEX designation
	NFVZ-3 St1	1	
	NFVZ-7 St1	2	
	NFVZ-12 St1	2	
	NFVZ-20 St1	4	
	NFVZ-3 St2	1	
	NFVZ-7 St2	2	
	NFVZ-12 St2	3	
	NFVZ-20 St2	6	

St3 version: special delivery.

* For mounting in non-zone.

Mounting in zone 22 or 21 – option.

Subject to alteration.